

# \*TB 9-5120-206-24

DEPARTMENT OF THE ARMY TECHNICAL BULLETIN

## CALIBRATION PROCEDURE FOR TORQUE WRENCH POWER-DYNE, MODEL PD-602

Headquarters, Department of the Army, Washington, DC

18 June 2008

*Distribution Statement A: Approved for public release; distribution is unlimited.*

### REPORTING OF ERRORS AND RECOMMENDING IMPROVEMENTS

You can improve this manual. If you find any mistakes or if you know of a way to improve these procedures, please let us know. Mail your letter or DA Form 2028 (Recommended Changes to Publications and Blank Forms) directly to: Commander, U.S. Army Aviation and Missile Command, ATTN: AMSAM-MMC-MA-NP, Redstone Arsenal, AL 35898-5000. A reply will be furnished to you. You may also send in your comments electronically to our E-mail address: [2028@redstone.army.mil](mailto:2028@redstone.army.mil) or by fax 256-842-6546/DSN 788-6546. For the World Wide Web use: <https://amcom2028.redstone.army.mil>. Instructions for sending an electronic 2028 can be found at the back of this manual.

SECTION		Paragraph	Page
	I. IDENTIFICATION AND DESCRIPTION		
	Test instrument identification .....	1	2
	Forms, Records & Reports .....	2	2
	Calibration description .....	3	2
	II. EQUIPMENT REQUIREMENTS		
	Equipment required .....	4	2
	Accessories required.....	5	2
	III. CALIBRATION PROCESS		
	Preliminary instructions.....	6	3
	Equipment setup .....	7	3
	Torque .....	8	5
	Final procedure .....	9	7

\*This bulletin supersedes TB 9-5120-206-35, dated 7 August 2003.

**SECTION I  
IDENTIFICATION AND DESCRIPTION**

**1. Test Instrument Identification.** This bulletin provides instructions for the calibration of Torque Wrench, Power-Dyne, Model PD-602. The manufacturer's manual was used as the prime data source in compiling these instructions. The equipment being calibrated will be referred to as the TI (test instrument) throughout this bulletin.

**a. Model Variations.** None.

**b. Time and Technique.** The time required for this calibration is approximately 1 hour, using the physical technique.

**2. Forms, Records, and Reports**

**a.** Forms, records and reports required for calibration personnel at all levels are prescribed by TB 750-25.

**b.** Adjustments to be reported are designated (R) at the end of the sentence in which they appear. When adjustments are in tables, the (R) follows the designated adjustment. Report only those adjustments made and designated with (R).

**3. Calibration Description.** TI parameters and performance specifications which pertain to this calibration are listed in table 1.

Table 1. Calibration Description

Test instrument parameters	Performance specifications
Torque	Range: 0 to 600 ft-lb Accuracy: $\pm 3\%$ of reading

**SECTION II  
EQUIPMENT REQUIREMENTS**

**4. Equipment Required.** Table 2 identifies the specific equipment to be used in this calibration procedure. This equipment is issued with Secondary Transfer Calibration Standards Set AN/GSM-287 and AN/GSM-705. Alternate items may be used by the calibrating activity. The items selected must be verified to perform satisfactorily prior to use and must bear evidence of current calibration. The equipment must meet or exceed the minimum use specifications listed in table 2. The accuracies listed in table 2 provide a four-to-one ratio between the standard and TI. Where the four-to-one ratio cannot be met, the actual accuracy of the equipment selected is shown in parenthesis.

**5. Accessories Required.** The accessories required for this calibration are common usage accessories, issued as indicated in paragraph 4 above, and are not listed in this calibration procedure.

Table 2. Minimum Specifications of Equipment Required

Common name	Minimum use specifications	Manufacturer and model (part number)
FORCE/TORQUE INDICATOR	Range: $\pm 0.1$ -3.06 mv/v Accuracy: $\pm 0.03\%$ indication	HBM, Model MGCPLUS (13589298)
TORQUE CELL NO. 1	Range: 0 to 300 ft-lb. Accuracy: $\pm 0.5\%$ of applied torque from 20% FS to FS	Lebow, Model 2133-126 Type 1 (MIS-26485)
TORQUE CELL NO. 2	Range: 400 to 618 ft-lb. Accuracy: $\pm 0.5\%$ of applied torque from 20% FS to FS	Lebow, Model 2133-127 Type 1 (MIS-26485)

### SECTION III CALIBRATION PROCESS

#### 6. Preliminary Instructions

- a. The instructions outlined in paragraphs 6 and 7 are preparatory to the calibration process. Personnel should become familiar with the entire bulletin before beginning the calibration.
- b. Items of equipment used in this procedure are referenced within the text by common name as listed in table 2.
- c. Unless otherwise specified, verify the result of each test and, whenever the test requirement is not met, take corrective action before continuing with the calibration. Adjustments required to calibrate the TI are included in this procedure. Additional maintenance information is contained in the manufacturer's manual for this TI.
- d. Unless otherwise specified, all controls and control settings refer to the TI.

#### 7. Equipment Setup

##### WARNING

HIGH VOLTAGE is used or exposed during the performance of this calibration. DEATH ON CONTACT may result if personnel fail to observe safety precautions. REDUCE OUTPUT(S) to minimum after each step within the performance check where applicable.

- a. Verify that TI is clean and free from defects that would impair its operation.
- b. Insure that equipment has been allowed to stabilize at ambient temperature.
- c. Position mounting plate on a stable and rigid work surface and secure with bolts.
- d. Assemble equipment as shown in figure 1.

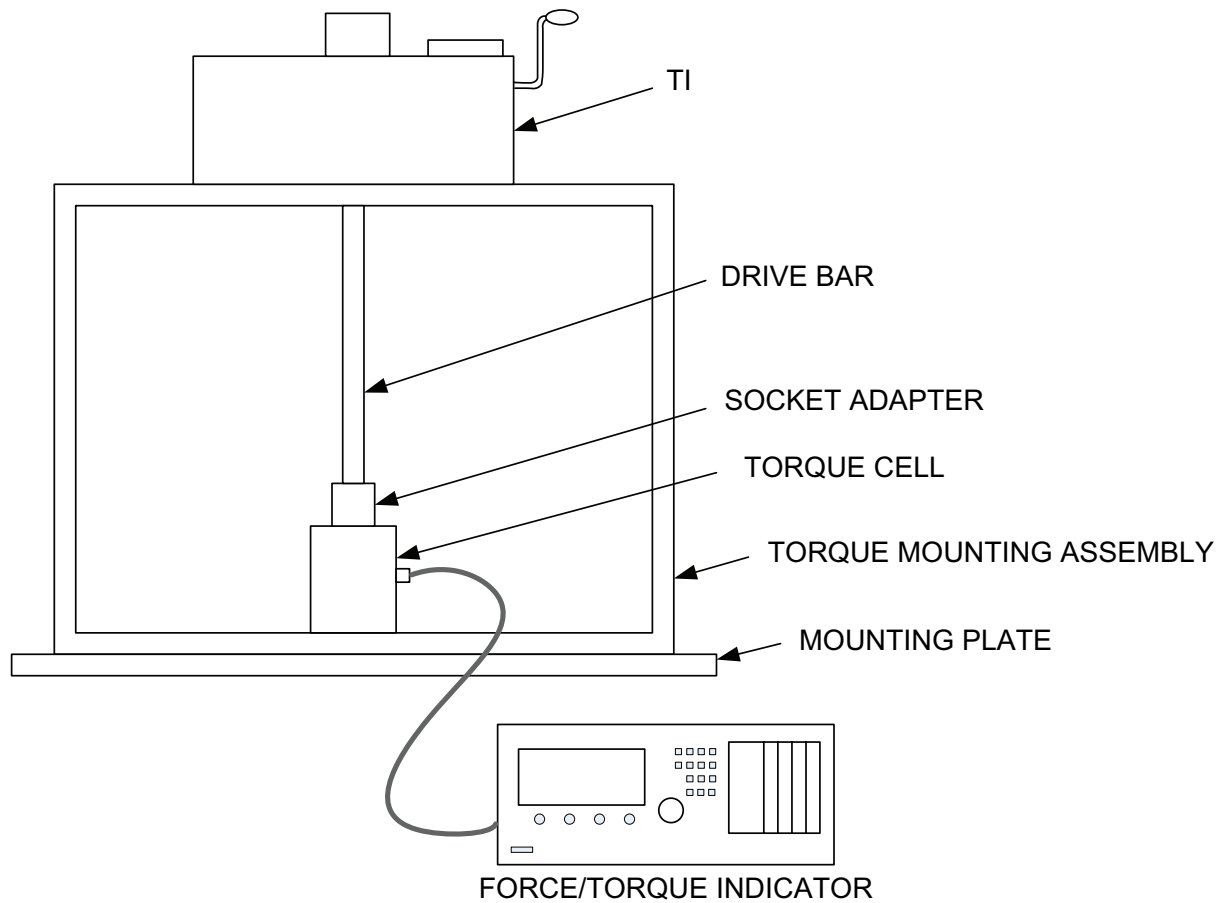





Figure 1. Torque - equipment setup.

e. Connect torque cell no. 1 to force/torque indicator, using cable supplied with force/torque indicator.

f. Connect force/torque indicator to appropriate power source. Turn power switch to **ON** and allow the unit to warm-up for 30 minutes. Select channel **3** using the **CHANNEL +** and **-** keys.

**NOTE**

Whenever direction of torque is changed (cw or ccw), force/torque indicator setup must be changed and TI must be exercised three times.

g. Press the **F4** key on the force/torque indicator until you see the   soft keys. Press the   soft keys as necessary to select torque cell no. 1 and ccw direction. Insure the serial number matches the torque cell being used.

h. Press the **F4** key on the force/torque indicator until you see the **UNIT** soft key. Press the **UNIT** soft key as necessary to select **ft-lb**.

i. Press the **SIGNAL ▲▼** to select the **GROSS** mode of operation. Press the **F4** key on the TI indicator until you see the **Acal** soft key. Press the **Acal** soft key as necessary to activate the **Acal** enunciator.

**8. Torque**

**a. Performance Check**

- (1) Set TI indicator to zero with no torque applied.
- (2) Exercise TI as follows:
  - (a) Turn crank handle cw to obtain an approximate full-scale indication on TI indicator. Force/torque indicator will indicate ccw reaction torque.
  - (b) After 30 seconds, turn crank handle ccw to obtain a zero indication on TI indicator.
  - (c) Repeat (a) and (b) above two times.
  - (d) Press the **F4** key on the force/torque indicator until you see **→0←** as soft key. Press the **→0←** soft key to zero force/torque indicator.
- (3) Operate TI cw to obtain indications listed in table 3. If load cell indications are not within limits specified, perform **b** below.

Table 3. Calibration Points

Test instrument indications (ft-lb)	Force/torque indicator indications	
	Min	Max
100	97	103
200	194	206
300	291	309
400 <sup>1</sup>	388	412
500	485	515
600	582	618

<sup>1</sup>Replace torque cell no. 1 with torque cell no. 2 and repeat paragraph 7 e through 8 a (2).

**NOTE**

The calibration points must be approached in the direction of increasing torque. If calibration point is passed, reduce torque and approach calibration point again.





- (4) Repeat 7 e through 8 (3) above, except turn crank handle ccw.
- (5) Turn TI crank handle cw to obtain a zero indication.

**b. Adjustments**

- (1) Apply torque in cw direction for TI indication of 100 ft-lb and record indication.
- (2) Repeat (1) above at 300 ft-lb.

**NOTE**

Whenever direction of torque is changed (cw or ccw), force/torque indicator setup must be changed and TI must be exercised three times.

(3) Press the **F4** key on the force/torque indicator until you see the   soft keys. Press the   soft keys as necessary to select torque cell no. 1 and cw direction. Insure the serial number matches the torque cell being used.

(4) Press the **F4** key on the force/torque indicator until you see the **UNIT** soft key. Press the **UNIT** soft key as necessary to select **ft-lb**.

(5) Press the **SIGNAL ▲▼** to select the **GROSS** mode of operation. Press the **F4** key on the TI indicator until you see the **Acal** soft key. Press the **Acal** soft key as necessary to activate the **Acal** enunciator.

(6) Repeat (1) and (2) above in ccw direction.

(7) If TI indication error is the same in both cw and ccw directions, perform (a) through (d) below.

- (a) Remove retaining ring from gage housing using allen wrench.
- (b) Remove lens (adhesive may be used for removing lens).
- (c) Apply torque for 300 ft-lb indication on force/torque indicator.
- (d) Rotate TI meter dial to indicate 300 (R).





(8) If TI indication error is not the same in both cw and ccw directions, adjust TI as indicated in (a) through (n) below.

- (a) Decrease torque for zero indication on TI meter.
- (b) Remove TI from equipment setup.
- (c) Back off SET SCREWS A and B (fig. 2) at least three turns each.
- (d) Tighten SET SCREW A until meter indicates 10 ft-lbs.
- (e) Adjust SET SCREW B until meter indicates 20 ft-lb.
- (f) Back off SET SCREW A approximately four turns.
- (g) Tighten SET SCREW B (counting turns) for 10 ft-lb indication on meter.

Record number of turns.

- (h) Back off SET SCREW B half the number of turns recorded in (g) above.
- (i) Tighten SET SCREW A for 10 ft-lb indication on meter.
- (j) Check spacing between SENSING UNIT HOUSING on reaction adapter and

WRENCH HOUSING (fig. 2). SENSING UNIT HOUSING should be approximately centered in WRENCH HOUSING.

(k) Press the **F4** key on the force/torque indicator until you see the   soft keys. Press the   soft keys as necessary to select torque cell no. 1 and ccw direction. Insure the serial number matches the torque cell being used.

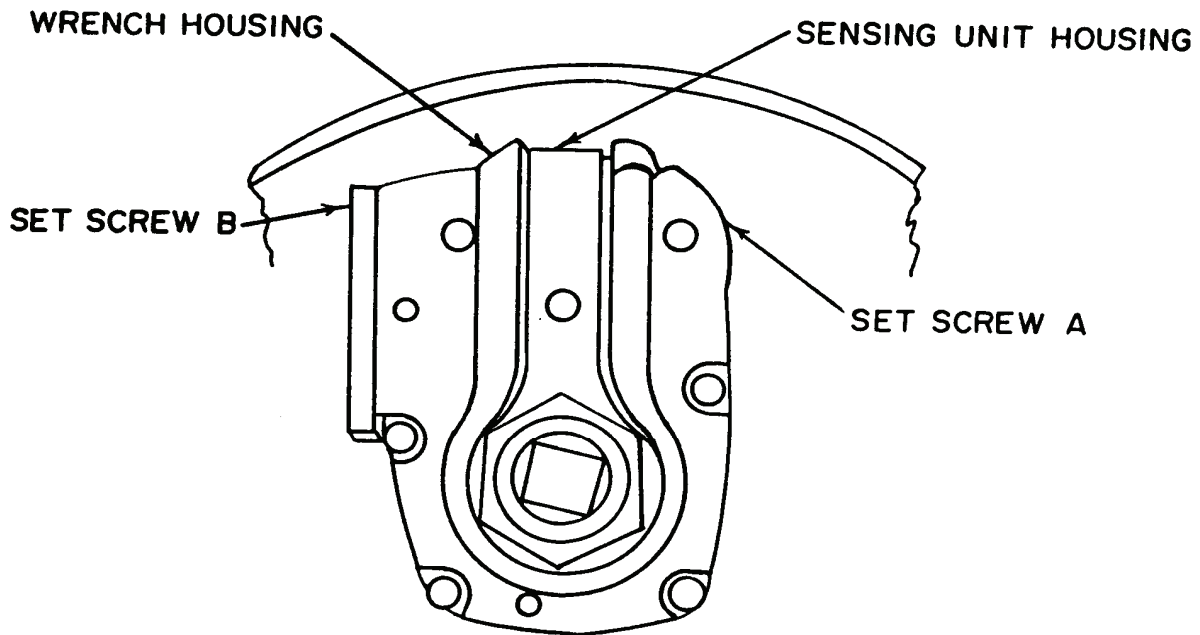

Figure 2. Calibration adjustments.

(l) Press the **F4** key on the force/torque indicator until you see the **UNIT** soft key. Press the **UNIT** soft key as necessary to select **ft-lb**.

(m) Press the **SIGNAL ▲▼** to select the **GROSS** mode of operation. Press the **F4** key on the TI indicator until you see the **Acal** soft key. Press the **Acal** soft key as necessary to activate the **Acal** enunciator.

(n) Connect equipment and repeat (1) through (6) above. If TI meter indication is not within  $\pm 3$  percent of force/torque indicator indication, repeat (7) above (R).

(o) Repeat paragraphs 7 e thru 7 i and 8 a above.

## 9. Final Procedure

- a. Deenergize and disconnect all equipment.
- b. Annotate and affix DA label/form in accordance with TB 750-25.





By Order of the Secretary of the Army:

Official:



JOYCE E. MORROW  
*Administrative Assistant to the  
Secretary of the Army*

0811205

GEORGE W. CASEY, JR.  
*General, United States Army  
Chief of Staff*

Distribution:

To be distributed in accordance with the initial distribution number (IDN) 342079, requirements for calibration procedure TB 9-5120-206-24.



## INSTRUCTIONS FOR SUBMITTING AN ELECTRONIC 2028

The following format must be used if submitting an electronic 2028. The subject line must be exactly the same and all fields must be included; however, only the following fields are mandatory: 1, 3, 4, 5, 6, 7, 8, 9, 10, 13, 15, 16, 17, and 27.

From: "Whomever" [whomever@redstone.army.mil](mailto:whomever@redstone.army.mil)  
To: <2028@redstone.army.mil

Subject: DA Form 2028

1. **From:** Joe Smith
2. **Unit:** home
3. **Address:** 4300 Park
4. **City:** Hometown
5. **St:** MO
6. **Zip:** 77777
7. **Date Sent:** 19-OCT -93
8. **Pub no:** 55-2840-229-23
9. **Pub Title:** TM
10. **Publication Date:** 04-JUL-85
11. **Change Number:** 7
12. **Submitter Rank:** MSG
13. **Submitter FName:** Joe
14. **Submitter MName:** T
15. **Submitter LName:** Smith
16. **Submitter Phone:** 123-123-1234
17. **Problem:** 1
18. **Page:** 2
19. **Paragraph:** 3
20. **Line:** 4
21. **NSN:** 5
22. **Reference:** 6
23. **Figure:** 7
24. **Table:** 8
25. **Item:** 9
26. **Total:** 123
27. **Text**

This is the text for the problem below line 27.





